

Bruciatori di gas ad aria soffiata

Blown gas burners

Brûleurs gaz à air soufflé

Gebläse-Gasbrenner

Quemadores de gas

Funzionamento bistadio
Two-stage operation
Fonctionnement à deux allures
Zweistufiger Betrieb
Funcionamiento de dos llama

COD.	MOD.	TYP.
3785813	RS 190	835 T1

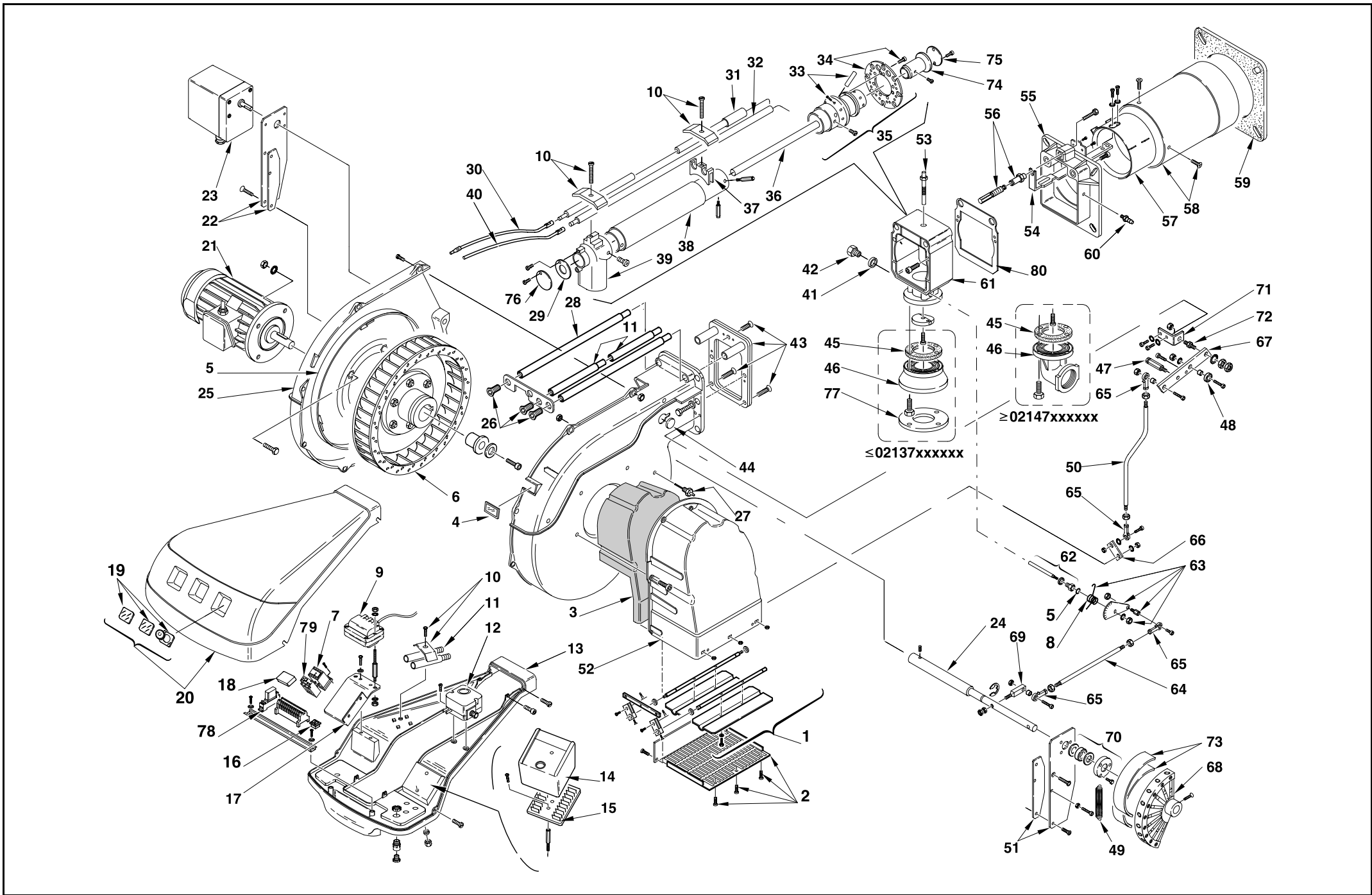

N.	COD.	DESCRIZIONE	DESCRIPTION	DESCRIPTION	BESCHREIBUNG	DENOMINACION	MATRICOLA BRUCIATORE BURNER SERIAL NUMBER MATRICULE BRULEUR BRENNER KENN-NUMMER MATRICULA QUEMADORES	RICAMBI CONSIGLIATI ADVISED PARTS RECHANGE CONSEIL EMPFOHLENE ERSATZTEILE RECAMBIOS A CONSEJADOS
								*
1	3012583	GRUPPO SERRANDA	AIR DAMPER ASSEMBLY	GROUPE VOLET AIR	LUFTKLAPPE	CONJUNTO REGISTRO AIRE	≤ 02406xxxxxx	
1	3013684	GRUPPO SERRANDA	AIR DAMPER ASSEMBLY	GROUPE VOLET AIR	LUFTKLAPPE	CONJUNTO REGISTRO AIRE	≥ 02416xxxxxx	
2	3003086	PROTEZIONE	GRID	PROTECTION	SCHUTZGITTER	PROTECION	≤ 02406xxxxxx	
2	3013683	PROTEZIONE	GRID	PROTECTION	SCHUTZGITTER	PROTECION	≥ 02416xxxxxx	
3	3012553	FONOASSORBENTE	SOUND DAMPING	INSONORISANT	GERÄUSCHDÄMMUNG	AISLAMIENTO ACÚSTICO	≤ 02406xxxxxx	C
3	3013682	FONOASSORBENTE	SOUND DAMPING	INSONORISANT	GERÄUSCHDÄMMUNG	AISLAMIENTO ACÚSTICO	≥ 02416xxxxxx	C
4	3003763	VISORE	INSPECTION WINDOW	VISEUR	SICHTFENSTER	VISOR		
5	3012573	ANELLO	PISTON SEAL	JOINT TORIQUE	LIPPENDICHTUNG	ANILLO		
6	3012555	GIRANTE	FAN	TURBINE	GEBLÄSERAD	TURBINA		C
7	3003637	CONTATTORE	CONTACTOR	CONTACTEUR	SCHÜTZ	CONTACTOR		C
8	3013204	MOLLA	SPRING	RESSORT	FEDER	MUELLE		B
9	3003847	TRASFORMATORE	TRANSFORMER	TRANSFORMATEUR	ZÜNDTRANSFORMATOR	TRANSFORMADOR		B
10	3003409	CAVALLOTTO	U BOLT	CAVALIER	BÜGELBOLZEN	FIJACION ELECTRODO		
11	3003956	PROLUNGA PERNO	BAR EXTENSION	RALLONGE DE GLISSIERE	VERLÄNGERUNG	EXTENSIÓN PERNO	≤ 02406xxxxxx	
11	3013687	PROLUNGA PERNO	BAR EXTENSION	RALLONGE DE GLISSIERE	VERLÄNGERUNG	EXTENSIÓN PERNO	≥ 02416xxxxxx	
12	3007444	PRESSOSTATO ARIA	AIR PRESSURE SWITCH	PRESSOSTAT AIR	LUFTDRUCKWÄCHTER	PRESOSTATO DEL AIRE		A
13	3012008	MENSOLA	BASE PLATE	PLAQUE DE SUPPORT	GRUNDPLATTE	REPISA	≤ 02188xxxxxx	
13	3014124	MENSOLA	BASE PLATE	PLAQUE DE SUPPORT	GRUNDPLATTE	REPISA	≥ 02198xxxxxx	
14	3013073	APPARECCHIATURA	CONTROL BOX	BOITE DE CONTROLE	STEUERGERÄT	CAJA CONTROL		B
15	3003784	MORSETTIERA	CONTROL BOX BASE	SOCLE	STECKSOCKEL	ZOCALO CAJA CONTROL		C
16	3003770	INTERRUTTORE	SWITCH	INTERRUPTEUR	SCHALTER	INTERUCTOR		C
17	3003957	SUPPORTO	SUPPORT	SUPPORT	HALTER	CORCHETE		
18	3012155	FILTRO ANTIDISTURBO	DEGLITCHER	FILTRE	ENTSTÖRER	FILTRO ANTI-INTERFERENCIA		C
19	3013678	MEMBRANA + VETRINO	MEMBRANE+VIEWING PORT	MEMBRANE+REGARD	MEMBRAN+VERSCHLUßSTOPFEN	MEMBRANA+MIRILLA		
20	3013119	COFANO	COVER	COFFRET	VERKLEIDUNG	ENVOLVENTE		
21	3012557	MOTORE	MOTOR	MOTEUR	MOTOR	MOTOR		C
22	3012585	PIASTRA	ANCHOR PLATE	PLATINE DE BLOCAGE	ARRETIERPLATTE	PLACA		
23	3012586	SERVOMOTORE	SERVOMOTOR	SERVOMOTEUR	STELLMOTOR	SERVOMOTOR		B
24	3012349	ALBERO	SHAFT	ARBRE	WELLE	ARBOLILLO		
25	3012587	GUSCIO	HALF-SHELL	COUVERCLE	HAUBE	CÀSCARA		
26	3003481	VITE	SCREW	VIS	SCHRAUBE	TORNILLO	≤ 02406xxxxxx	
26	3013681	VITE	SCREW	VIS	SCHRAUBE	TORNILLO	≥ 02416xxxxxx	
27	3003891	RACCORDO	CONNECTOR	MAMELON	NIPPEL	RACORD		C
28	3012013	PERNO	BAR	GLISSIERE	BOLZEN	PERNO	≤ 02406xxxxxx	C
29	3012588	DISCO	DISC	DISQUE	SCHEIBE	TUBO LLAMA		
30	3003795	COLLEGAMENTO ELETTRODO	H.T. LEAD	CONNEXION POUR ELECTRODE	VERBINDUNG FÜR ELEKTRODE	CABLE ELECTRODO		A
31	3012016	ELETTRODO	ELECTRODE	ELECTRODE PORCELAINE	ELEKTRODE	ELECTRODO		A
32	3012178	SONDA	PROBE	SONDE	FÜHLER	SONDA		A
33	3012025	TUBETTO	TUBE	TUYAU	RÖHRCHEN	TUBITO		
34	3012027	DISCO	DISC	DISQUE	SCHEIBE	TUBO LLAMA		A
35	3012589	DISTRIBUTORE	GAS HEAD	DISTRIBUTEUR	GASVERTEILER	DISTRIBUIDOR		
36	3012590	TUBO INTERNO	INTERIOR TUBE	TUYAU INTERIEUR	INNERER ROHR	TUBO INTERNO		
37	3012193	SUPPORTO	SUPPORT	SUPPORT	HALTER	CORCHETE		
38	3012591	TUBO ESTERNO	EXTERIOR TUBE	TUYAU EXTERIEUR	AUSSERER ROHR	TUBO EXTERNO		

N.	COD.	DESCRIZIONE	DESCRIPTION	DESCRIPTION	BESCHREIBUNG	DENOMINACION	MATRICOLA BRUCIATORE BURNER SERIAL NUMBER MATRICULE BRULEUR BRENNER KENN-NUMMER MATRICULA QUEMADORES	RICAMBI CONSIGLIATI ADVISED PARTS RECHANGE CONSEIL EMPFOHLENE ERSATZTEILE RECAMBIOS A CONSEJADOS *
39	3012042	GOMITO	ELBOW	COUDE	SCHLITTEN	DISCO		
40	3012043	COLLEGAMENTO SONDA	PROBE LEAD	CONNEXION POUR SONDE	VERBINDUNG FÜR SONDE	CABLE SONDA DE IONIZACIÓN		A
41	3007088	GUARNIZIONE	SEAL	RONDELLE	METALLDICHTUNG	JUNTA		B
42	3003863	TAPPO	PLUG	BOUCHON A VIS	SCHRAUBSTÖPSEL	TAPÓN		
43	3013685	GRUPPO PIASTRE	PLATES ASSEMBLY	GROUPE PLATINES	PLATTEN GROUPE	CONJUNTO PLACAS	≥ 02416xxxxxx	
44	3003996	TAPPO	PLUG	BOUCHON A VIS	SCHRAUBSTÖPSEL	TAPÓN		
45	3005482	GUARNIZIONE	SEAL	RONDELLE	METALLDICHTUNG	JUNTA		B
46	3006803	FLANGIA E GOMITO	FLANGE AND ELBOW	BRIDE ET COUDE	ANSCHLUSSFLANSCH - GASVERTEILER	BRIDA Y CODO	≥ 02147xxxxxx	
46	3012592	FLANGIA	FLANGE	BRIDE	ANSCHLUSSFLANSCH	BRIDA	≤ 02137xxxxxx	
47	3012352	PERNO	BAR	GLISSIERE	BOLZEN	PERNO		C
48	3003841	CUSCINETTO	BEARING	ROULEMENT	LAGER	COJINETE		
49	3012356	MOLLA	SPRING	RESSORT	FEDER	MUELLE		
50	3012646	TIRANTE	TIE ROD	TIRANT	GESTÄNGE	TIRANTE		C
51	3012594	PIASTRA	ANCHOR PLATE	PLATINE DE BLOCAGE	ARRETIERPLATTE	PLACA		
52	3012595	BOCCA D'ASPIRAZIONE	AIR INTAKE	BOITIER D'ASPIRATION	ANSAUGÖFFNUNG	BOCA ASPIRACION	≤ 02406xxxxxx	
53	3012049	VITE	SCREW	VIS	SCHRAUBE	TORNILLO		
54	3013698	SQUADRETTA	SQUARE	EQUERRE - SUPPORT	HALTER	ESCUADRA	≥ 02416xxxxxx	
55	3012559	FRONTONE	FRONT PIECE	FACADE	VORDERTEIL	TUBO LLAMA	≤ 02406xxxxxx	
56	3013291	GRUPPO REGOLATORE	CONTROL DEVICE	GROUPE OBTURATION	DRUCKREGULIERUNG	GRUPO REGULACION	≤ 02406xxxxxx	C
56	3012639	GRUPPO REGOLATORE	CONTROL DEVICE	GROUPE OBTURATION	DRUCKREGULIERUNG	GRUPO REGULACION	≥ 02416xxxxxx	C
57	3012560	OTTURATORE	SHUTTER	OBTURATEUR	SCHIEBER	OBTURADOR		C
58	3012596	IMBUTO FIAMMA	END CONE	EMBOUT GUEULARD	FLAMMENROHR	TUBO EXTREMO	≤ 02406xxxxxx	B
58	3013699	IMBUTO FIAMMA	END CONE	EMBOUT GUEULARD	FLAMMENROHR	TUBO EXTREMO	≥ 02416xxxxxx	
59	3012562	SCHERMO	FLANGE GASKET	ECRAN THERMIQUE	FLASCHDICHTUNG	JUNTA AISLANTE		A
60	3003322	RACCORDO	CONNECTOR	MAMELON	NIPPEL	RACORD		C
61	3012597	MANICOTTO	MANIFOLD	MANCHON	GASANSCHLUSS	MANGUITO	≤ 02382000584	
61	3013166	MANICOTTO	MANIFOLD	MANCHON	GASANSCHLUSS	MANGUITO	≥ 02382000585; ≤ 02406xxxxxx	
62	3012598	ALBERO MANICOTTO	BUTTERFLY VALVE SHAFT	AXE DE LA VANNE PAPILLON	SPINDEL GASDROSSEL	ARBORILLO MANGUITO		
63	3012599	QUADRANTE	GRADUATE SECTOR	SECTEUR GRADUE	SKALENSEGMENT	CUADRANTE		
64	3012600	TIRANTE	TIE ROD	TIRANT	GESTÄNGE	TIRANTE	≤ 02406xxxxxx	C
64	3013897	TIRANTE	TIE ROD	TIRANT	GESTÄNGE	TIRANTE	≥ 02416xxxxxx	C
65	3006098	SNODO SFERICO	PIN JOINT	CHAPE A ROTULE	KUGELGELENK	ARTICOLACION ESFERICA		C
66	3012601	LEVA	LEVER	LEVIER	HEBEL	PALANCA		C
67	3012354	LEVA	LEVER	LEVIER	HEBEL	PALANCA		C
68	3012358	CAMMA	CAM	CAME	NOCKEN	EXCÉNTRICO		C
69	3012350	LEVA	LEVER	LEVIER	HEBEL	PALANCA		C
70	3012357	CUSCINETTO	BEARING	ROULEMENT	LAGER	COJINETE		
71	3012602	SUPPORTO	SUPPORT	SUPPORT	HALTER	CORCHETE		
72	3012603	PERNO	BAR	GLISSIERE	BOLZEN	PERNO		C
73	3006097	MOLLA	SPRING	RESSORT	FEDER	MUELLE		A
74	3012604	DIFFUSORE	GAS NOZZLE	DIFFUSEUR	GAS VERTEILER	DIFUSOR		
75	3012605	DISCO	DISC	DISQUE	SCHLEIBE	TUBO LLAMA		B

N.	COD.	DESCRIZIONE	DESCRIPTION	DESCRIPTION	BESCHREIBUNG	DENOMINACION	MATRICOLA BRUCIATORE BURNER SERIAL NUMBER MATRICULE BRULEUR BRENNER KENN-NUMMER MATRICULA QUEMADORES	RICAMBI CONSIGLIATI ADVISED PARTS RECHANGE CONSEIL EMPFOHLENE ERSATZTEILE RECAMBIOS A CONSEJADOS
76	3012606	DISCO	DISC	DISQUE	SCHEIBE	TUBO LLAMA		*
77	3006589	GUARNIZIONE	SEAL	RONDELLE	METALLDICHTUNG	JUNTA	≤ 02137xxxxxx	B
78	3013407	RELE' TERMICO	THERMAL OVERLOAD	RELAIS THERMIQUE	ÜBERSTROMAUSLÖSER	RÉLE TÉRMICO	≥ 02195000418	C
79	3013676	RELE' TERMICO	THERMAL OVERLOAD	RELAIS THERMIQUE	ÜBERSTROMAUSLÖSER	RÉLE TÉRMICO		C
80	3013856	GUARNIZIONE	SEAL	RONDELLE	METALLDICHTUNG	JUNTA	≥ 02416xxxxxx	B

A = Ricambi per dotazione minima - Spare parts for minimum fittings - Pièces détachées pour équipement minimum - Ersatzteile für minimale Ausstattung - Recambios para equipamiento mínimo

A+B = Ricambi per dotazione base di sicurezza - Spare parts for basic safety fittings - Pièces détachées pour équipement standard de sécurité - Ersatzteile für Sicherheitsgrundausrüstung - Recambios para equipamiento básico de seguridad

A+B+C = Ricambi per dotazione estesa di sicurezza - Spare parts for extended safety fittings - Pièces détachées pour équipement complet de sécurité - Ersatzteile für erweiterte Sicherheitsausstattung - Recambios para equipamiento general de seguridad



RIELLO S.p.A.
I - 37045 Legnago (VR)
Tel. +39.0442.630111
[http:// www.rielloburners.com](http://www.rielloburners.com)