

Gruppi termici in acciaio a condensazione
Chaudières en acier à condensation
Steel condensing boilers
Brennwert-stahlheizkessel
Stalen verwarmingsketels met rookgascondensor
Grupos térmicos de condensación de acero

COD.	MOD.	TYP.
4031820	Tau Unit 55	
4031821	Tau Unit 75	

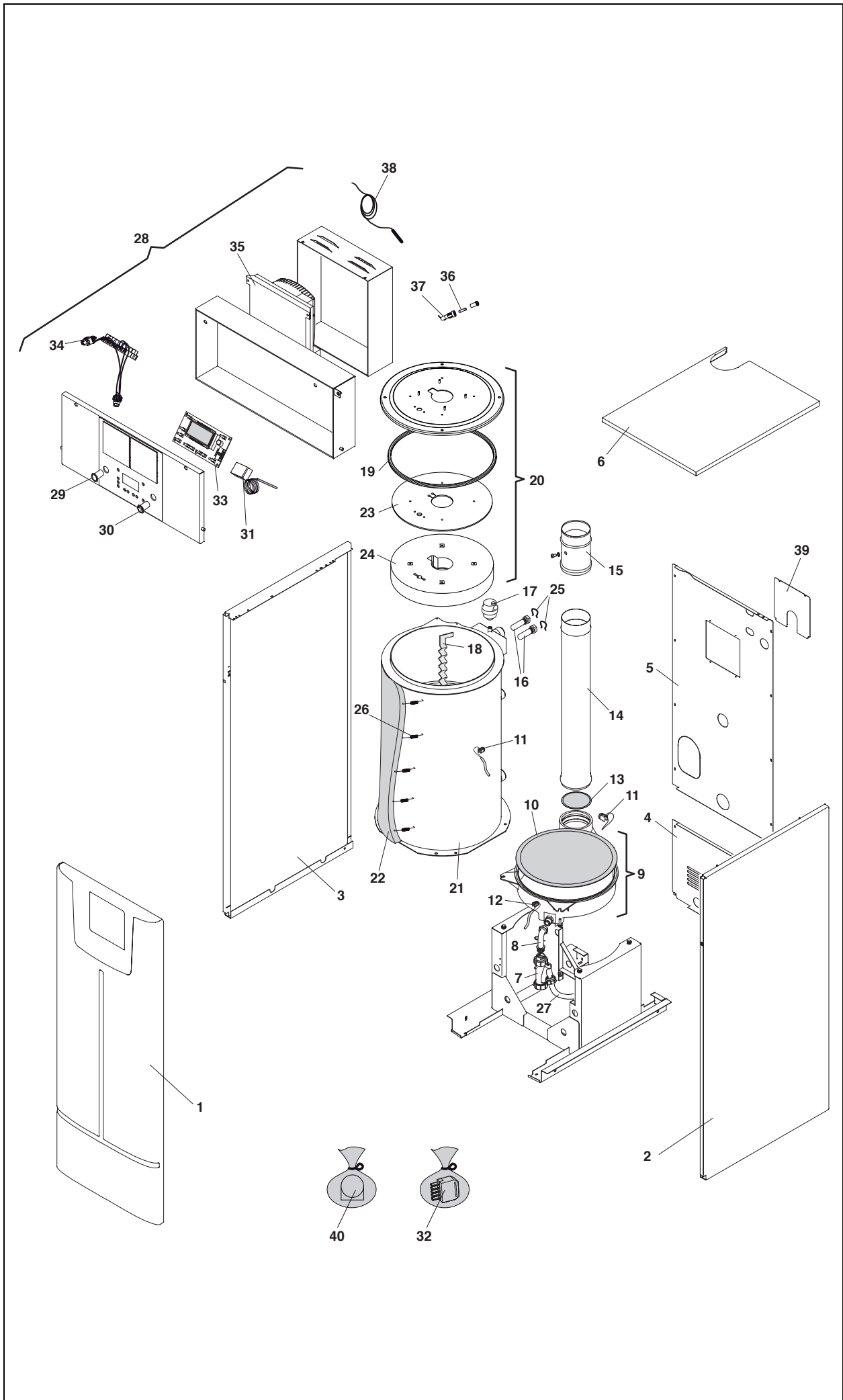

N.	COD.	RC	4031820	4031821	DESCRIZIONE	DESCRIPTION	DESCRIPTION	BESCHREIBUNG	BESCHRIJVING	DESCRIPCIÓN
1	4035815	•	•		Pannello anteriore	Panneau antérieur	Front panel	Paneel vorn	Voorpaneel	Panel anterior
2	4035816	•	•		Pannello destro	Panneau de droite	Right panel	Rechte Blende	Rechter paneel	Panel derecho
3	4035817	•	•		Pannello sinistro	Panneau de gauche	Left Panel	Linke Blende	Linker paneel	Panel izquierdo
4	4035818	•	•		Pannello posteriore inferiore	Panneau postérieur inférieur	Back lower panel	Hintere untere Blende	Onderste achterpaneel	Panel posterior inferior
5	4035819	•	•		Pannello posteriore superiore	Panneau postérieur supérieur	Upper back panel	Hintere obere Blende	Bovenste achterpaneel	Panel posterior superior
6	4035820	•	•		Coperchio	Capot	Cover	Deckel	Deksel	Tapa
7	4035821	•	•		Sifone	Siphon	Siphon	Syphon	Sifon	Sifón
8	4035823	•	•		Tubo sifone	Tube siphon	Pipe	Syphonrohr	Sifonbuis	Tubo sifón
9	4035822	•	•		Chiusura camera fumi	Fermeture chambre fumée	Fumes chamber closure	Verschluss Rauchgaskammer	Sluiting rookkamer	Cierre cámara humos
10	4035824	•	•		Guarnizione	Joint	Washer	Dichtung	Pakking	Junta
11	4035825	•	•		Sonda	Sonde	Detector	Auslasssonde	Sonde	Sonda
12	4035826	•	•		Termostato	Thermostat	Thermostat	Thermostat	Thermostaat	Termostato
13	4035827	•	•		Guarnizione siliconica	Joint de silicone	Washer	Dichtung	Silicone pakking	Junta silicónica
14	4035828	•	•		Tubo scarico fumi	Tube évacuation fumées	Exhaust tube	Rauchablassrohr	Rookafvoerbuis	Tubo descarga humos
15	4035829	•	•		Tubo camino	Tube	Flue duct	Kaminrohr	Schoorsteenbuis	Tubo chimenea
16	4035830	•	•		Tappo portasonde	Doigt de gant	Plug	Deckel	Sonedop	Tapón portasondas
17	4048774	•	•		Valvola sfiato aria	Purgeur automatique	Air venting plug	Luftablassventil	Ontluchtingsklep	Válvula venteo aire
18	4035831	•			Turbolatore	Accrocheur-flamme	Diffuser disc	Stauscheibe	Turbulentieeenheid	Turbolatore
18	4035869	•			Turbolatore	Accrocheur-flamme	Diffuser disc	Stauscheibe	Turbulentieeenheid	Turbolatore
19	4051318	•	•		Confezione cordone	Joint corde porte 2m	Cord kit	Packung Schnur	Verpakking koord	Envase cordón
20	4035832	•	•		Chiusura camera fumi	Fermeture chambre fumées	Fumes chamber closure	Verschluss Rauchgaskammer	Sluiting rookkamer	Cierre cámara humos
21	4035833	•			Scambiatore	Corps de chauffe	Heat exchanger	Austauscher	Wisselaar	Cambiador
21	4035870	•			Scambiatore	Échangeur	Condensing exchanger assembly	Austauscher	Wisselaar	Cambiador
22	4035834	•			Isolamento corpo caldaia	Isolation corps chaudière	Protection	Isolierung Kesselkörper	Isolatie ketelbehuizing	Aislamiento cuerpo caldera
22	4035871	•			Isolamento corpo caldaia	Isolation corps chaudière	Protection	Isolierung Kesselkörper	Isolatie ketelbehuizing	Aislamiento cuerpo caldera
23	4035835	•	•		Isolamento camera fumi	Isolant boite fumée	Protection	Isolierung	Isolatie rookkamer	Aislamiento cámara humos
24	4035836	•	•		Isolamento	Isolation	Protection	Isolierung	Isolatie	Aislamiento
25	4050903	•	•		Molla	Ressort	Spring	Feder	Veer	Muelle
26	4034608	•	•		Molla	Ressort	Spring	Feder	Veer	Muelle
27	4035837	•	•		Tubo scarico condensa	Tube	Condensing pipe	Abflussrohr Kondenswasser	Condensafvoerslang	Tubo descarga condensación

N.	COD.	DESCRIZIONE	DESCRIPTION	BESCHREIBUNG	BESCHRIJVING	DESCRIPCIÓN
		4031821				
		4031820				
	RC					
28	4035838	Quadro elettrico	Tableau électrique	Schalttafel	Elektrisch paneel	Cuadro eléctrico
28	4035876	● Quadro elettrico	● Tableau électrique	● Schalttafel	● Elektrisch paneel	● Cuadro eléctrico
29	4035839	● Lampada rossa	● Voyant rouge	● Rote Lampe	● Rode lamp	● Lámpara roja
30	4035840	● Interruttore	● Interrupteur	● Ausschalter	● Schakelaar	● Interruptor
31	4035841	● Termostato sicurezza	● Thermostat sécurité	● Sicherheitsthermostat	● Veiligheidsthermostaat	● Termostato seguridad
32	4035842	● Spina	● Fiche	● Stecker	● Stekker	● Clavija
33	4035843	● Scheda	● Platine	● Karte	● Kaart	● Tarjeta
34	4035844	● Cablaggio quadro elettrico	● Câblage tableau électrique	● Schalttafelverkabelung	● Bekabeling elektrisch paneel	● Cableado cuadro eléctrico
35	4035845	● Scheda controllo LMU	● Fiche de contrôle LMU	● Steuerkarte LMU	● Controlekaart LMU	● Tarjeta control LMU
35	4035877	● Scheda controllo LMU	● Fiche de contrôle LMU	● Steuerkarte LMU	● Controlekaart LMU	● Tarjeta control LMU
36	4050868	● Portafusibile	● Porte-fusibles	● Sicherungshalter	● Zekeringhouder	● Portafusibles
37	3006211	● Fusibile 6,3 A	● Fusible 6,3 A	● Feinsicherung 6,3 A	● Zekering 6,3A	● Fusible 6,3A
38	4035846	● Sonda LMU	● Sonde LMU	● Auslasssonde LMU	● Sonde LMU	● Sonda LMU
39	4035847	● Chiusura	● Fermeture	● Verschluss	● Sluiting	● Cierre
40	4035848	● Sonda esterna	● Sonde externe	● Außensonde	● Externe sonde	● Sonda exterior

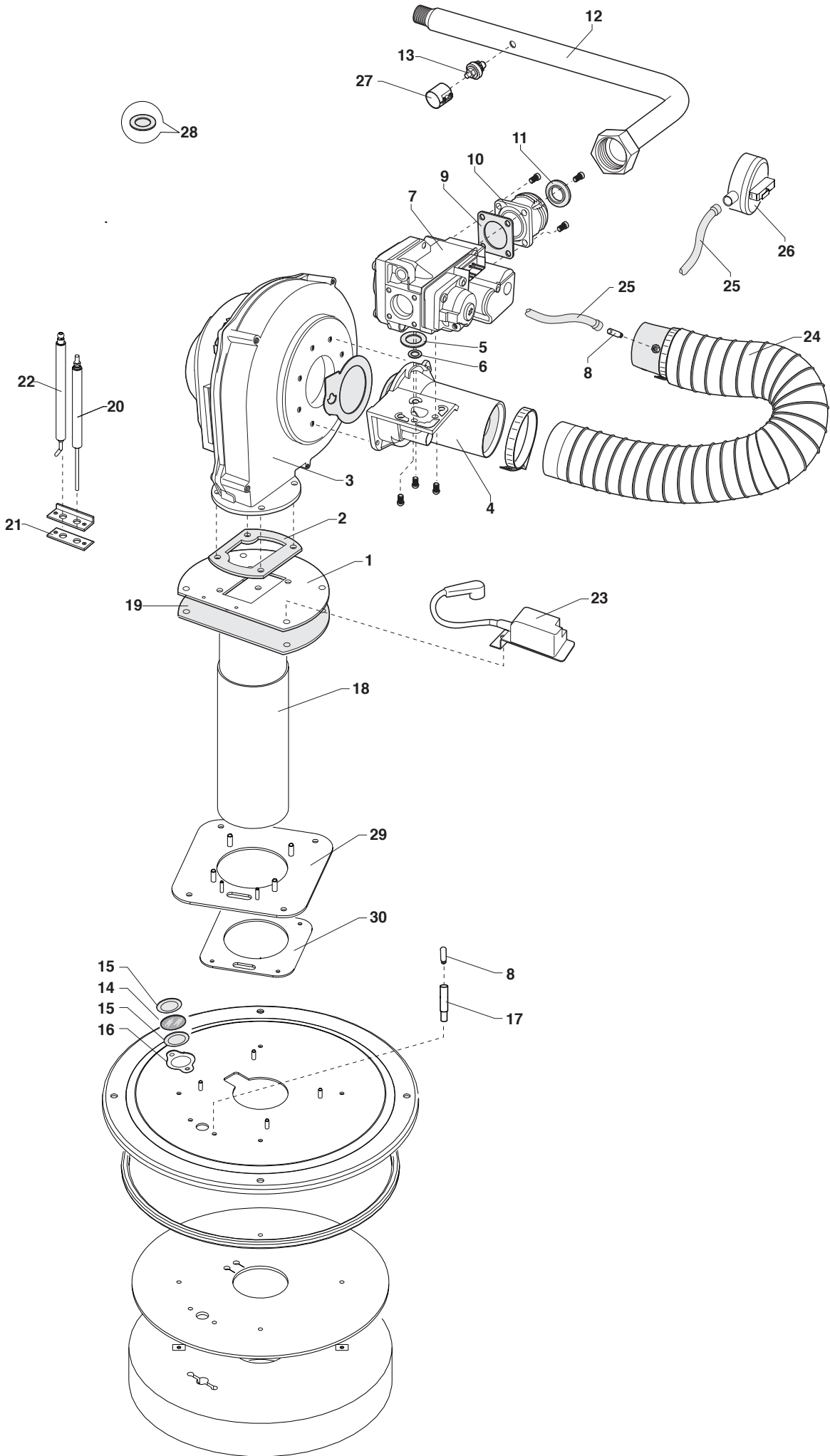

N.	COD.	RC	DESCRIZIONE	DESCRIPTION	DESCRIPTION	BESCHREIBUNG	BESCHRIJVING	DESCRIPCIÓN
		4031821						
27	4035865	●	Coperchio pressostato	Couvercle de pressostat	Pressure diff.switch cover	Abdeckung Druckwächter	Deksel drukmeter	Tapa presostato
28	4035866	●	Diaframma disco	Diaphragme disque	Gas diaphragm	Scheibendiaphragma	Schijf diafragma	Diafragma disco
28	4035875	●	Diaframma disco	Diaphragme disque	Gas diaphragm	Scheibendiaphragma	Schijf diafragma	Diafragma disco
29	4035867	●	Flangia bruciatore	Bride brûleur	Burner flange	Flansch	Branderfiens	Brida quemador
30	4035868	●	Guarnizione flangia	Joint bride	Washer	Dichtung	Flens pakking	Junta brida



RIELLO

Riello S.p.A.

37048 Z.A.I. di San Pietro di Legnago (Verona) Via Ing. Pilade Riello, 7
Tel. 0442/630.111 - Fax 0442/22378 <http://www.riello.it>
archivio <http://ics.riello.it>
