

Bruciatore di gasolio
Light oil burner
Brûleur fioul domestique
Ölbrenner
Quemadores de gasóleo

Funzionamento bistadio
Two-stage operation
Fonctionnement à deux allures
Zweistufiger Betrieb
Funcionamiento a dos llama

COD.	MOD.	TYP.
3475614	RL 190	673 T1

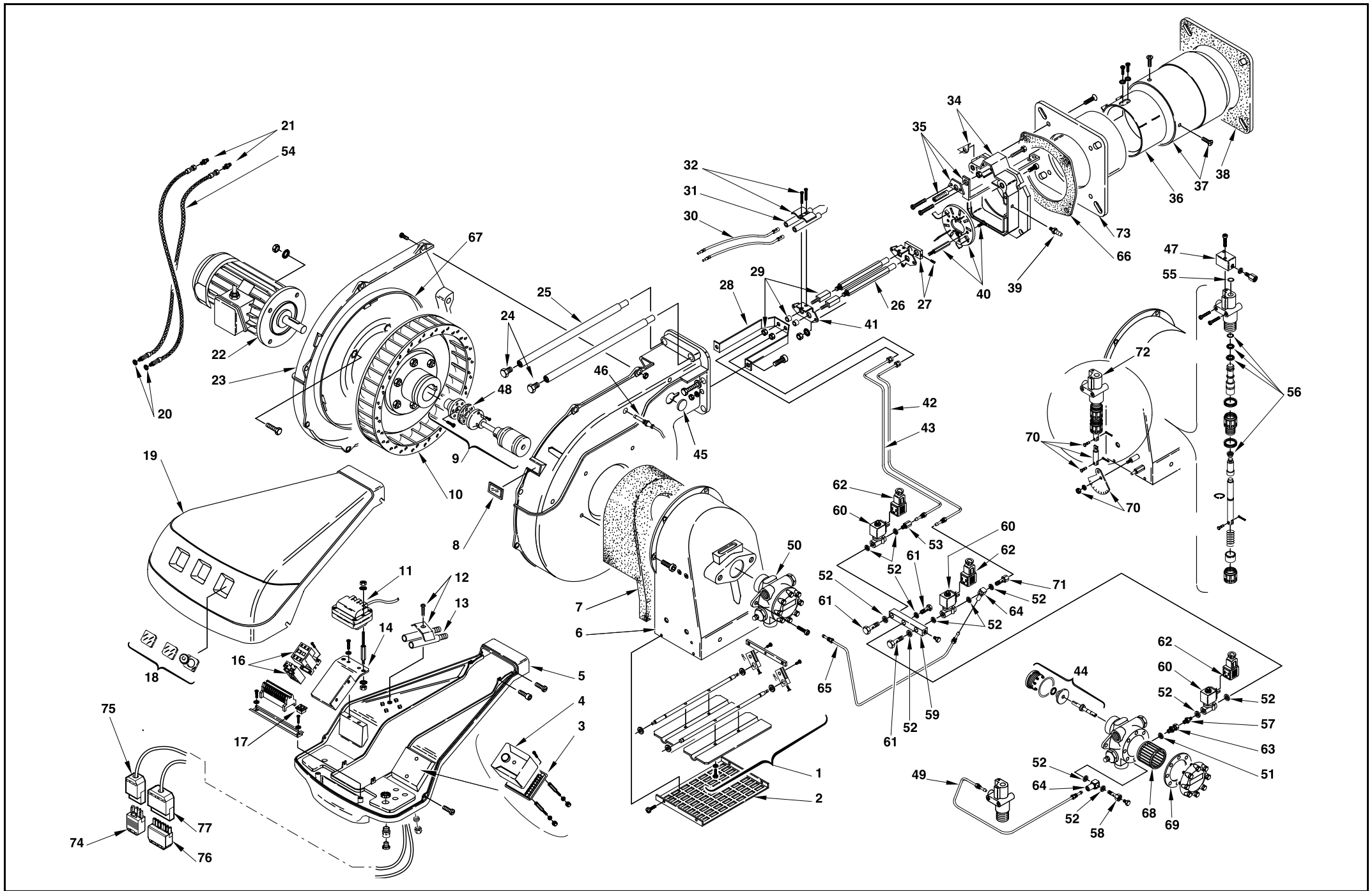

N.	COD.	DESCRIZIONE	DESCRIPTION	DESCRIPTION	BESCHREIBUNG	DENOMINACION	MATRICOLA BRUCIATORE BURNER SERIAL NUMBER MATICULE BRULEUR BRENNER KENN-NUMMER MATRICULA QUEMADORES	RICAMBI CONSIGLIATI ADVISED PARTS RECHARGE CONSEIL EMPFOHLENE ERSATZTEILE RECAMBIOS ACONSEJADOS
								**
1	3012551	GRUPPO SERRANDA	AIR DAMPER ASSEMBLY	GROUPE VOLET AIR	LUFTKLAPPE	CONJUNTO REGISTRO AIRE		
2	3003086	PROTEZIONE	GRID	PROTECTION	SCHUTZGITTER	PROTECION		
3	3003784	MORSETTIERA	CONTROL BOX BASE	SOCLE	STECKSOCKEL	ZOCALO CAJA CONTROL		C
4	3013071	APPARECCHIATURA	CONTROL BOX	BOITE DE CONTROLE	STEUERGERÄT	CAJA CONTROL		A
5	3012008	MENSOLA	BASE PLATE	PLAQUE DE SUPPORT	GRUNDPLATTE	REPISA		
6	3012552	BOCCA D'ASPIRAZIONE	AIR INTAKE	BOITIER D'ASPIRATION	ANSAUGÖFFNUNG	BOCA ASPIRACION		
7	3012553	FONOASSORBENTE	SOUND DAMPING	INSONORISANT	GERÄUSCHDÄMMUNG	AISLAMIENTO ACUSTICO		
8	3003763	VISORE	INSPECTION WIN	WISEUR	SICHTFENSTER	VISOR		
9	3012554	GRUPPO GIUNZIONE	DRIVE COUPLING	ACCOUPLMENT	KUPPLUNG	ACOPLADOR IMPULSOR		A
10	3012555	GIRANTE	FAN	TURBINE	GEBLÄSERAD	TURBINA		C
11	3012488	TRASFORMATORE	TRANSFORMER	TRANSFORMATEUR	ZÜNDTRANSFORMATOR	TRANSFORMADOR		B
12	3003409	CAVALLOTTO	U BOLT	CAVALIER	BÜGELBOLZEN	FIJACION ELECTRODO		
13	3003956	PROLUNGA PERNO	BAR EXTENSION	RALLONGE DE GLISSIERE	VERLÄNGERUNG	PROLUNGACION PERNO		
14	3003957	SUPPORTO	SUPPORT	SUPPORT	HALTER	SOPORTE		
15								
16	3012556	RELE' TERMICO + CONTATTORE	OVERLOAD + CONTACTOR	RELAIS THERMIQUE + CONTACTEUR	ÜBERSTROMAUSLÖSER + SCHÜTZ	RÉLE TÉRMICO + CONTACTOR		C
17	3003770	INTERRUTTORE	SWITCH	INTERRUPTEUR	SCHALTER	INTERRUPTOR		C
18	3003962	VETRINO	VIEWING PORT	REGARD	SCHAUGLAS	MIRILLA		
19	3013119	COFANO	COVER	COFFRET	VERKLEIDUNG	ENVOLVENTE		
20	3007164	GUARNIZIONE	SEAL	RONDELLE	METALLDICHTUNG	JUNTA		B
21	3006181	RACCORDO	CONNECTOR	MAMELON	NIPPEL	RACORD		C
22	3012557	MOTORE	MOTOR	MOTEUR	MOTOR	MOTOR		C
23	3012558	GUSCIO	HALF-SHELL	COUVERCLE	HAUBE	CASCARA		
24	3003481	VITE	SCREW	VIS	SCHRAUBE	TORNILLO		
25	3003970	PERNO	BAR	GLISSIERE	BOLZEN	PERNO		
26	3003789	PROLUNGA PERNO	BAR EXTENSION	RALLONGE DE GLISSIERE	VERLÄNGERUNG	PROLUNGACION PERNO		
27	3003790	PIASTRA	ANCHOR PLATE	PLATINE DE BLOCAGE	ARRETIERPLATTE	PLACA		
28	3003971	SUPPORTO	SUPPORT	SUPPORT	HALTER	SOPORTE		
29	3003814	PORTASPRUZZO	NOZZLE HOLDER	PULVERISATEUR	DÜSENSTOCK	PORTABOQUILLA		C
30	3003973	COLLEGAMENTO	H.T. LEAD	CABLE H.T.	ZÜNDKABEL	CABLES ELECTRODOS		A
31	3003796	ELETTRODO	ELECTRODE	ELECTRODE PORCELAINE	ELEKTRODE	ELECTRODO		A
32	3003495	CAVALLOTTO	U BOLT	CAVALIER	BÜGELBOLZEN	FIJACION ELECTRODO		
33								
34	3013165	FRONTONE	FRONT PIECE	FACADE	VORDERTEIL	SOPORTE QUEMADORE		
35	3003982	SQUADRETTA	SQUARE	EQUERRE-SUPPORT	HALTER	ESQUADRA		
36	3012560	OTTURATORE	SHUTTER	OBTURATEUR	SCHIEBER	OBTURADOR		C
37	3012561	IMBUTO FIAMMA	END CONE	EMBOUT GUEULARD	FLAMMENROHR	TUBO EXTREMO		B
38	3012562	SCHERMO	FLANGE GASKET	ECRAN THERMIQUE	FLANSCHDICHTUNG	JUNTA AISLANTE		A
39	3003322	RACCORDO	CONNECTOR	MAMELON	NIPPEL	RACORD		C
40	3012563	ELICA	DIFFUSER DISC	ACCROCHE FLAMME	STAUSCHEIBE	DISCO ESTABILIZADOR		A
41	3003815	SUPPORTO	SUPPORT	SUPPORT	HALTER	SOPORTE		
42	3012564	TUBO	TUBE	TUYAUTERIE	DRUCKROHR	TUBO		
43	3012565	TUBO	TUBE	TUYAUTERIE	DRUCKROHR	TUBO		
44	3000805	ORGANO DI TENUTA	PUMP SEAL	ORGANE D'ETANCHEITE	WELLENDICHTUNG	CONJUNTO ESTANQUIDAD		

N.	COD.	DESCRIZIONE	DESCRIPTION	DESCRIPTION	BESCHREIBUNG	DENOMINACION	MATRICOLA BRUCIATORE BURNER SERIAL NUMBER MATRICULE BRULEUR BRENNER KENN-NUMMER MATRICULA QUEMADORES	RICAMBI CONSIGLIATI ADVISED PARTS RECHANGE CONSEIL EMPFOHLENE ERSATZTEILE RECAMBIOS ACONSEJADOS
45	3003996	TAPPO	PLUG	BOUCHON A VIS	SCHRAUBSTÖPSEL	TAPÓN		A
46	3003779	FOTORESISTENZA	P.E. CELL	CELLULE	FOTOWIDERSTAND	FOTORESISTENCIA		A
47	3012566	COLLETTORE	MANIFOLD	COLLECTEUR	SAMMLER	COLECTOR		
48	3004821	DISCO ELASTICO	DRIVE DISC	DISQUE ELASTIQUE	KUPPLUNGSSCHEIBE	DISCO ELASTICO		A
49	3012567	TUBO	TUBE	TUYAUTERIE	DRUCKROHR	TUBO		
50	3006369	POMPA	PUMP	POMPE	PUMPE	BOMBA		C
51	3007079	GUARNIZIONE	SEAL	RONDELLE	METALLDICHTUNG	JUNTA		B
52	3007077	GUARNIZIONE	SEAL	RONDELLE	METALLDICHTUNG	JUNTA		B
53	3006719	RACCORDO	CONNECTOR	MAMELON	NIPPEL	RACORD		C
54	3006182	TUBO FLESSIBILE	TUBE	TUYAUTERIE	DRUCKROHR	TUBO FLEXIBLE		A
55	3003823	ANELLO	PISTON SEAL	JOINT TORIQUE	LIPPENDICHTUNG	ANILLO		B
56	3003820	ANELLO	PISTON SEAL	JOINT TORIQUE	LIPPENDICHTUNG	ANILLO		B
57	3012568	RACCORDO	CONNECTOR	MAMELON	NIPPEL	RACORD		C
58	3012003	PERNO	SCREW	VIS CREUSE	HOHLKERNSCHRAUBE	PERNO		C
59	3012569	COLLETTORE	MANIFOLD	COLLECTEUR	SAMMLER	COLECTOR		
60	3012570	VALVOLA	SOLENOID VALVE	SOUPAPE ELECTRIQUE	ELEKTROVENTIL	VALVULA		B
61	3006721	PERNO	SCREW	VIS CREUSE	HOHLKERNSCHRAUBE	PERNO		C
62	3006953	PRESA	SOCKET	PRISE	STECKERBUCHSE	CONNECTOR MACHO		C
63	3012547	RACCORDO	CONNECTOR	MAMELON	NIPPEL	RACORD		C
64	3006722	RACCORDO	CONNECTOR	MAMELON	NIPPEL	RACORD		C
65	3012571	TUBO	TUBE	TUYAUTERIE	DRUCKROHR	TUBO		
66	3012572	SCHERMO	FLANGE GASKET	ECRAN THERMIQUE	FLANSCHDICHTUNG	JUNTA AISLANTE		A
67	3012573	ANELLO	PISTON SEAL	JOINT TORIQUE	LIPPENDICHTUNG	ANILLO		B
68	3006787	FILTRO	FILTER	FILTRE	PUMPENFILTER	FILTRO		A
69	3006292	GUARNIZIONE	SEAL	RONDELLE	PUMPENDICHTUNG	JUNTA		A
70	3012574	QUADRANTE	GRADUATE SECTOR	SECTEUR GRADUE	SKALENSEGMENT	SECTOR GRADUADO		
71	3012575	PERNO	SCREW	VIS CREUSE	HOHLKERNSCHRAUBE	PERNO		C
72	3003825	MARTINETTO	HYDRAULIC JACK	VERIN AIR	DRUCKKOLBEN FÜR LUFTKLAPPE	HIDRAULICO DE AIRE		C
73	3012576	BOCCAGLIO	BLAST TUBE	GUEULARD	BRENNERFLANSCH	TUBO LLAMA		
74	3006948	SPINA 4 POLI	4 POLE PLUG	FICHE 4 POLES	STECKER 4 POLEN	CONEC.HEMBRA DE 4 CONTA.		
75	3006949	PRESA 4 POLI	4 POLE SOCKET	PRISE 4 POLES	STECKERBUCHSE 4 POLE.	CONEC.MACHO DE 4 CONTA.		
76	3006938	PRESA 7 POLI	7 POLE SOCKET	PRISE 7 POLES	STECKERBUCHSE 7 POLE.	CONEC.MACHO DE 7 CONTA.		
77	3006937	SPINA 7 POLI	7 POLE PLUG	FICHE 7 POLES	STECKER 7 POLEN	CONEC.HEMBRA DE 7 CONTA.		

**

A = Ricambi per dotazione minima - Spare parts for minimum fittings - Pièces détachées pour équipement minimum - Ersatzteile für minimale Ausstattung - Recambios para equipamiento mínimo

A+B = Ricambi per dotazione base di sicurezza - Spare parts for basic safety fittings - Pièces détachées pour équipement standard de sécurité - Ersatzteile für Sicherheitsgrundausrüstung - Recambios para equipamiento básico de seguridad

A+B+C = Ricambi per dotazione estesa di sicurezza - Spare parts for extended safety fittings - Pièces détachées pour équipement complet de sécurité - Ersatzteile für erweiterte Sicherheitsausstattung - Recambios para equipamiento general de seguridad



RIELLO S.p.A.
Via degli Alpini 1
I - 37045 Legnago (VR)
Tel.: +39.0442.630111 Fax: +39.0442.630375
[http:// www.rielloburners.com](http://www.rielloburners.com)